



Installation Manual

External Models

BC2680RA

BC2680RA5

BC2180RA

BC2180RA5

**To be installed and serviced only
by an authorised person**

**This appliance is not suitable for
use as a pool heater**

The "authorised installing person" is
responsible for:

1. Correct commissioning of this
appliance.
2. Ensure unit performs to the
specifications stated on the
rating label.
3. Demonstrate operation of unit to
customer before leaving.
4. Hand these instructions to
customer.

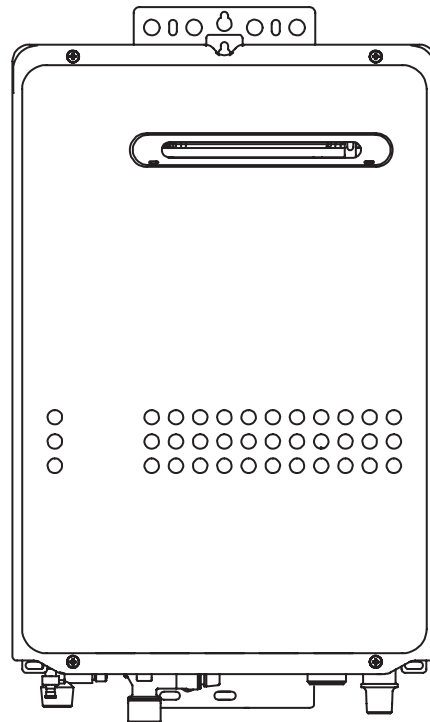

This appliance must be installed in accordance with the manufacturer's installation instructions, AS/NZS5601, AS/NZS3500.4, AS3000 wiring regulations and all Local Building, Water and Gas fitting regulations.

Failure to install this appliance in accordance with these installation instructions may void warranty

AU Service Department: 1300 30 70 37
NZ Service Department: 0800 54 33 52

In the interest of continued product improvement, Bosch reserves the right to alter these specifications without notice.





Contents

1. Included Accessories	4
2. Optional Accessories	4
3. Dimensions	5
4. Component Details	6
5. Before Installation	7
6. Specifications	8
7. Choosing Installation Site	9
8. Installation Clearances	10
9. Installation	12
10. Gas Piping	13
11. Water Piping	14
12. Condensate Piping	16
13. Electrical Wiring	17
14. Maintenance	20
15. Trial Operation	20
WATER QUALITY	22



Installation Manual

Robert Bosch
(Australia) Pty. Ltd.

CONDENSING GAS WATER HEATER

BC2680RA BC2680RA5
BC2180RA BC2180RA5 (Outdoor Installation)

Potential dangers from accidents during installation and use are divided into the following three categories. Closely observe these warnings, they are critical to your safety.



DANGER

DANGER indicates an imminently hazardous situation which, if not avoided, will result in death or serious injury.



WARNING

WARNING indicates a potentially hazardous situation which, if not avoided, could result in death or serious injury.



CAUTION

CAUTION indicates a potentially hazardous situation which, if not avoided, may result in minor or moderate injury.

WARNING: If the information in this manual is not followed exactly, a fire or explosion may result causing property damage, personal injury or death.



Prohibited



Disconnect
Power



Earth



Be sure to do



CAUTION

Requests to Installers

- In order to use the water heater safely, read this installation manual carefully, and follow the installation instructions.
- Failures and damage caused by erroneous work or work not as instructed in this manual are not covered by the warranty.
- Check that the installation was done properly in accordance with this Installation Manual upon completion.
- After completing installation, please either place this Installation Manual in a plastic pouch and attach it to the side of the water heater, or hand it to the customer to retain for future reference.



CAUTION

- The water heater must be commissioned including checking gas supply pressures at maximum demand.
- The operation of the water heater should be explained including normal operation & regular maintenance.



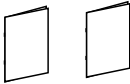

1. Included Accessories

The following accessories are included with the unit. Check for any missing items before starting installation.

Part	Shape	Q'ty	Part	Shape	Q'ty
Anchoring Screw		5	Owner's Guide, Installation Manual (this document)		1 each

2. Optional Accessories

The accessories listed below are not included with the units, but may be necessary for installation.

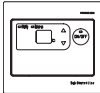
Part	Shape	Q'ty	Part	Shape	Q'ty
Main Controller (YPRM67XBN)		1	Bathroom Controller (YPRS67XBN)		1
Sub Controller (YPRP62XBN)		1			

- Maximum two Sub controllers can be used. See P.14 for details.



3. Dimensions

<Unit : mm>

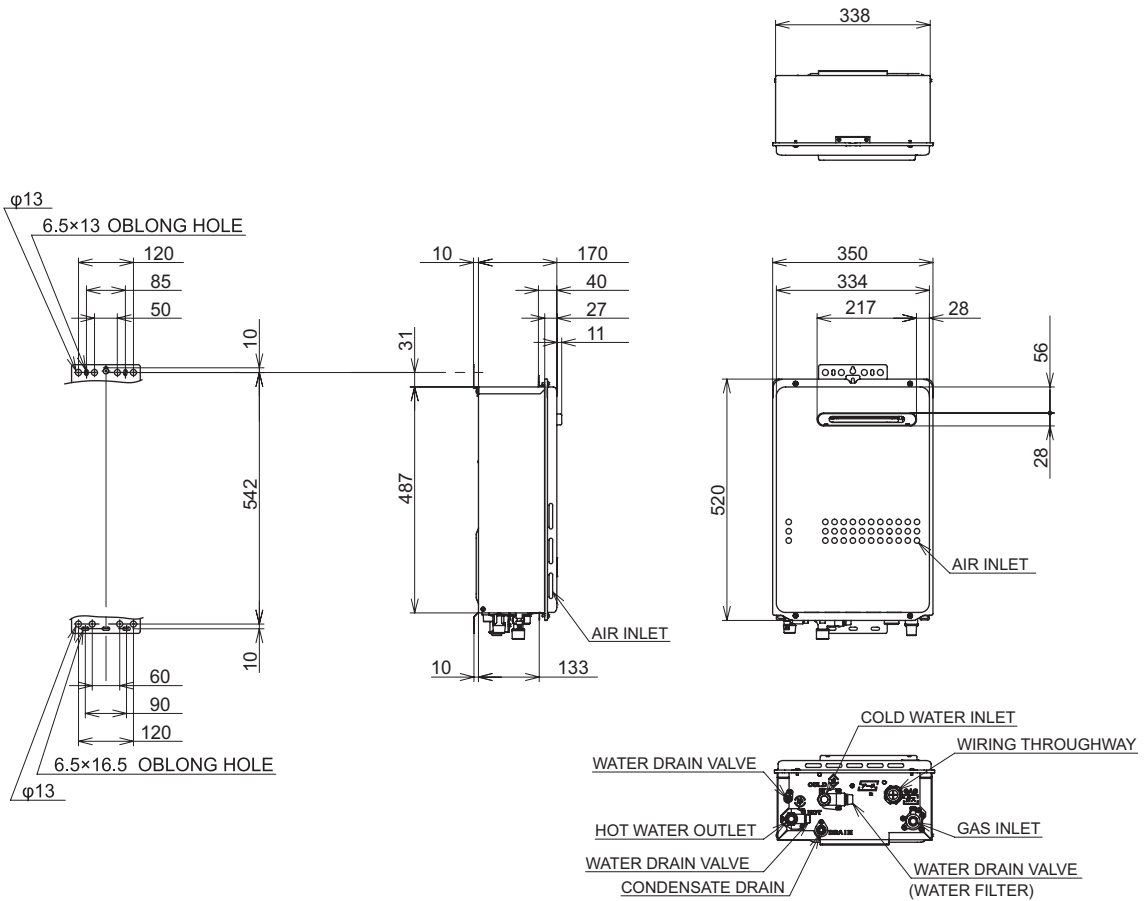

HEIGHT OF EACH FITTING FROM BOTTOM OF CASE

HOT WATER OUTLET	45
COLD WATER INLET	58
GAS INLET	50
CONDENSATE DRAIN	30

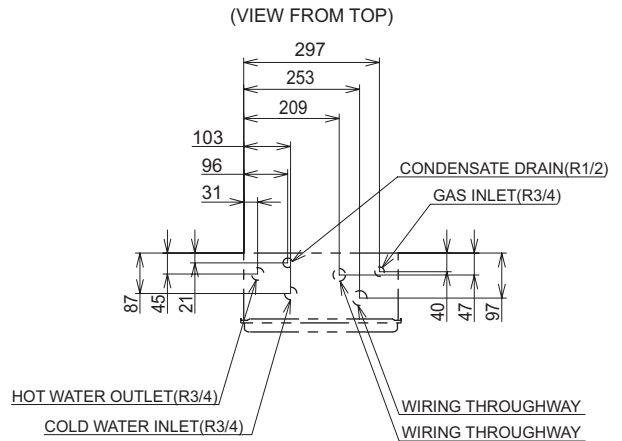



4. Component Details

• BC2680RA series, BC2180RA series

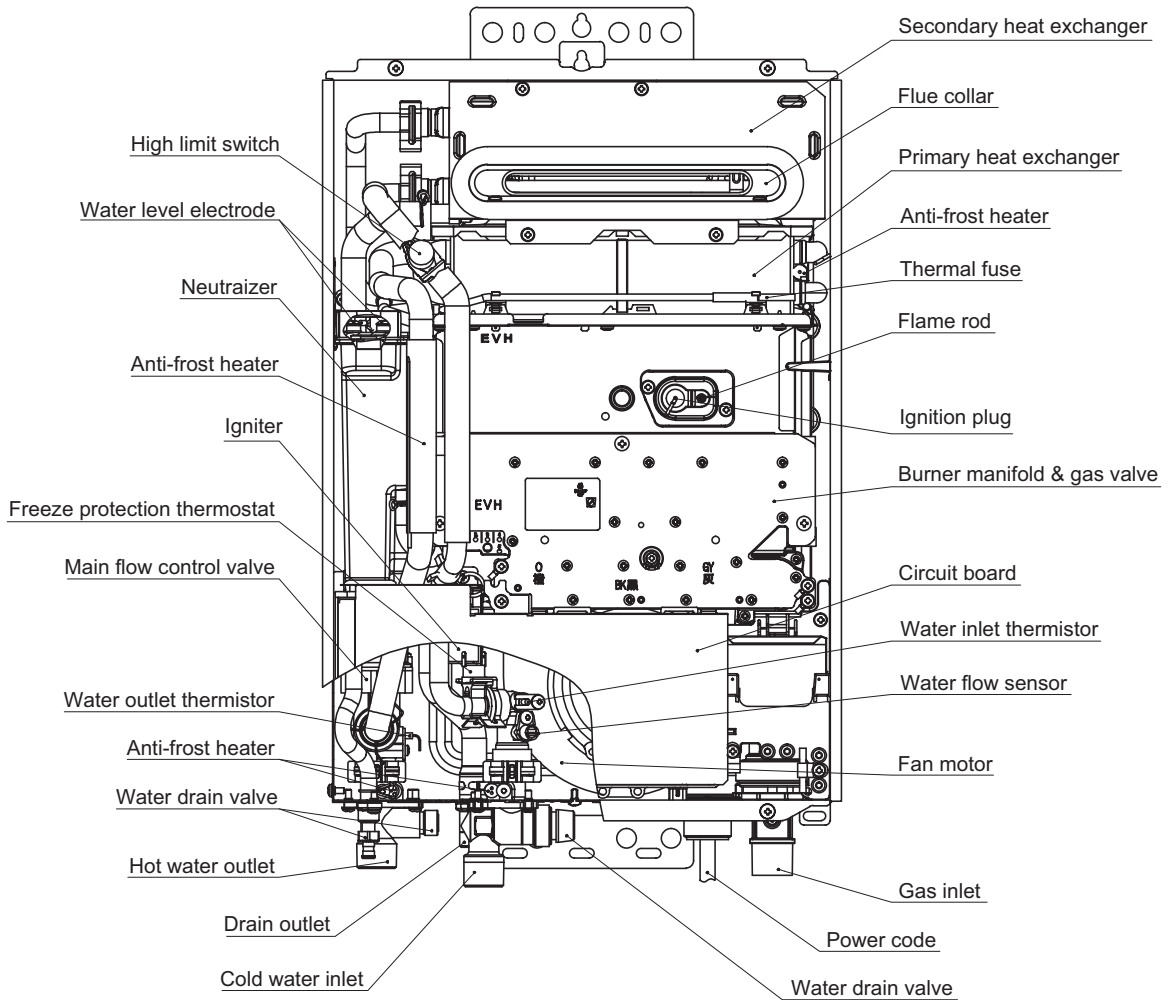



5. Before Installation



WARNING

Check the Gas

- Check that the data plate (located inside of front cover) or a temporary label (located on the front cover) indicates the correct type of gas.
- Check that the gas supply line is sized for BC2680RA(5): 176 MJ/hr, BC2180RA(5): 147 MJ/hr for this unit.
- DO NOT OPERATE WITH ANY OTHER GAS TYPE.

Check the Power

- The power supply required is 240/230VAC, at 50Hz. Using the incorrect voltage may result in fire or electric shock.

Warning labels

- Located on the left side of the casing -PLEASE READ THESE LABELS CAREFULLY!

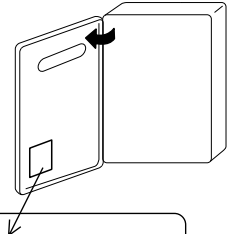

For NG Gas

BOSCH

MODEL	XXXXXXXX
GAS TYPE	: NG
GAS CONSUMPTION	: xx MJ/hr
HEAT OUTPUT	: xx kW
ELECTRICAL RATING	: AC240/230V 50Hz
RATED POWER	: xx W
HOT WATER SUPPLY CAPACITY	: xxL/min RAISED xx°C
<u>GAS PRESSURE TEST POINT</u>	



CAUTION

Do Not Use Equipment for Purposes Other Than Those Specified

- Do not use for other than increasing the temperature of the water supply, as unexpected accidents may occur as a result.

Check Water Supply Quality

- If the water supply is hard, acidic or otherwise impure, treat the water with approved methods in order to ensure full warranty coverage. See water quality statement on page 22.

Frost Protection

- When installed, power to the unit must be kept switched on, otherwise the appliance should be drained. This prevents water freezing, and causing damage to the water heater.



6. Specifications

- Specifications may be changed without prior notice.
- The capacity may differ slightly, depending on the water pressure, water supply, piping conditions, and water temperature.

Specifications

Model Name		BC2680RA	BC2680RA5	BC2180RA	BC2180RA5
Approval certification number		AGA xxxx			
Type	Installation	Outdoor, Wall Mounted			
	Air Supply/Exhaust	Power Flue			
Operating Pressure		200 -1,000 kPa			
Minimum Flow Rate		2.5 L/min.			
Dimensions		520mm (Height) x 350mm (Width) x 170mm (Depth)			
Weight		xx kg		xx kg	
Water Holding Capacity		xx L		xx L	
Connection Sizes	Water Inlet	R 3/4 (20mm)			
	Hot Water Outlet	R 3/4 (20mm)			
	Gas Inlet	R 3/4 (20mm)			
	Water Outlet (Drain water)	R 1/2 (15mm)			
Power Supply	Supply	230 / 240 VAC (50Hz)			
	Consumption	xxW	Freeze Prevention xxW	xxW	Freeze Prevention xxW
Accessories		Anchoring Screws			

Performance

Item		Maximum Performance	
Gas Consumption	NG	xxx MJ/hr	xxx MJ/hr
	LP	xxx MJ/hr	xxx MJ/hr
Maximum Hot Water Capacity	25°C Rise	26 L/min.	21 L/min.



7. Choosing Installation Site

* Locate the appliance in an area where water leakage from the unit or connections will not result in damage to the area adjacent to the appliance or to the lower floors of the structure. When such locations cannot be avoided, it is recommended that a suitable drain pan, adequately drained, be installed under the appliance. The pan must not restrict combustion air flow.

DANGER

- This water heater is for outdoor installation only. Never install it indoors. Do not enclose the termination with corrugated metal or other materials.

This will cause carbon monoxide poisoning and a potential fire hazard.

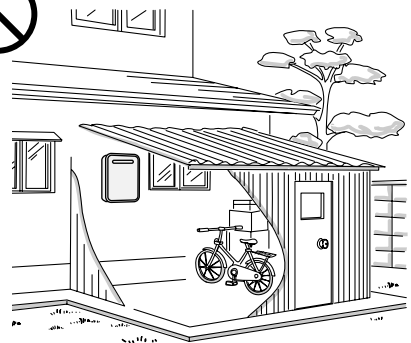
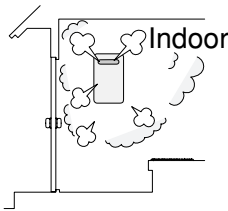

WARNING

- Avoid places where fires are common, such as those where petrol, benzene and adhesives are handled, or places in which corrosive gases (ammonia, chlorine, sulfur, ethylene compounds, acids) are present. May result in fire.
- Avoid installation in places where dust or debris will accumulate. Dust may block the air-supply opening, causing the performance of the device fan to drop and incomplete combustion to occur as a result.
- Avoid installation in places where special chemical agents (e.g., hair spray or spray detergent) are used. Ignition failures and malfunction may occur as a result.
- Carbon Monoxide Poisoning Hazard. Do not install this water heater in a mobile home, recreation vehicle or on a boat.



Prohibited

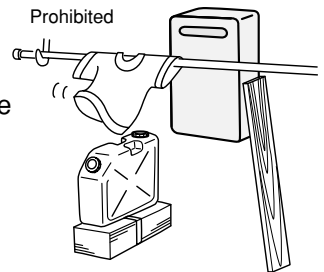

**CAUTION**

- Install the water heater in a location where it is free from obstacles and stagnant air.
- Consult with the customer concerning the location of installation.
- Do not install the water heater near staircases or emergency exits.
- Do not install the water heater where the exhaust will blow on outer walls or material not resistant to heat. Also consider the surrounding trees and animals.

The heat and moisture from the water heater may cause discoloration of walls and resinous materials, or corrosion of aluminium materials.

- Do not locate the vent termination directed towards a window or any other structure which has glass or wired glass facing the termination.
- Install in a location where the exhaust gas flow will not be affected by fans or range hoods.
- Take care that noise and exhaust gas will not affect neighbours.
- Avoid installation where the unit will be exposed to excessive winds.
- Before installing, make sure that the vent termination will have the proper clearances according to AS/NZS5601, or your local authority.
- On combustible surfaces e.g. weatherboards etc. it is not required to install a fire proof back board.



Prohibited

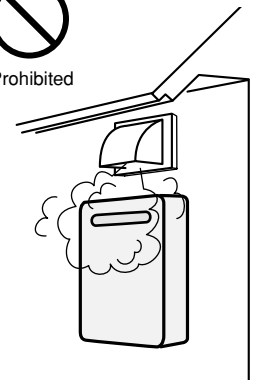

8. Installation Clearances

**WARNING**

Before installing, check for the following:

The location of the flue terminal must comply with the clearances shown on this page. If you are unsure about clearances not indicated here, in general refer to AS/NZS5601, or your local authority. In Western Australia refer to the WA Office of Energy rules and regulations.

Flue outlet must be free from any combustible material.

**CLEARANCES FOR FLUE TERMINAL (front of heater)**

The location of the flue terminal must comply with the clearances shown on this page. If you are unsure about clearances not indicated here, in general refer to AS/NZS5601, or your local authority. In Western Australia refer to the WA Office of Energy rules and regulations.

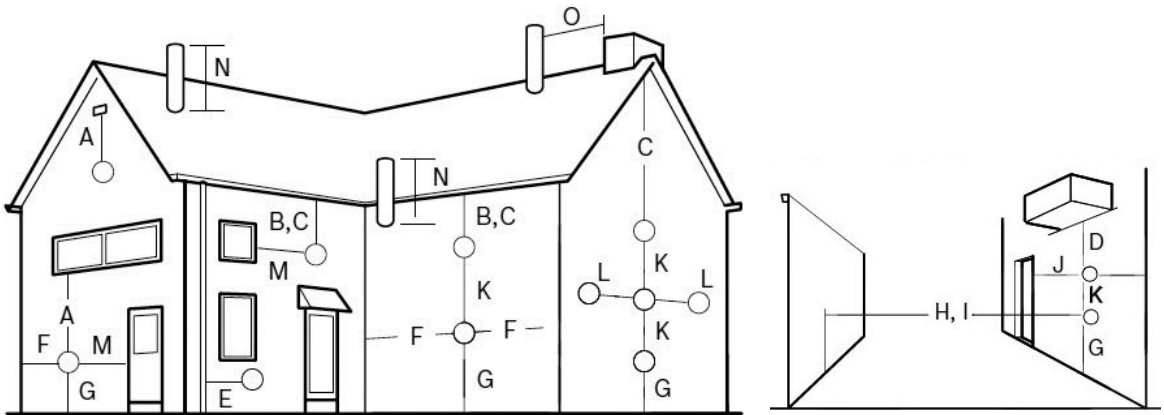
**Key to illustration**

Balanced flue terminal position		
Terminal Position		Minimum Spacing
A	Directly below, above or alongside an opening window, air vent or other ventilation opening	1,500mm
B	Below guttering, drain pipes or soil pipes	75mm
C	Below eaves	300mm
D	Below balconies or a car port roof*	300mm
E	From vertical drain pipes or soil pipes	75mm
F	From internal or external corners	300mm
G	Above adjacent ground, roof or balcony level	300mm
H	From a surface facing the terminal	1,500mm
I	From a terminal facing the terminal	1,200mm
K	Vertically from a terminal on the same wall	1,500mm
L	Horizontally from a terminal on the wall	300mm
M	Adjacent to opening	1,500mm
N	Above intersection with roof	500mm
O	For a vertical structure on the roof	500mm



9. Installation

Securing to the wall



Be sure to do

- Installation must conform with all local building, water or Gas Regulations or AS/NZS5601.
- The weight of the device will be applied to the wall. If the strength of the wall is not sufficient, reinforcement must be done to prevent the transfer of vibration.
- Do not drop or apply unnecessary force to the device when installing. Internal parts may be damaged and may become highly dangerous.
- Install the unit on a vertical wall and ensure that it is level.
- Insure no additional pressure is applied to the pipework.

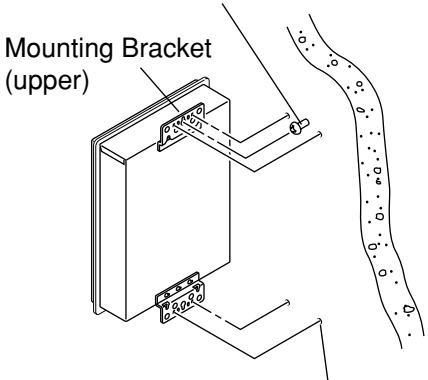
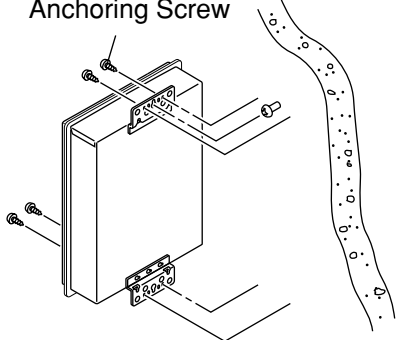
Item	Check	Illustration
Locating Screw Holes	<div style="border: 2px solid black; padding: 5px; text-align: center;">  CAUTION </div> <ul style="list-style-type: none"> • When installing with bare hands, take caution to not inflict injury. • Be careful not to hit electrical wiring, gas, or water piping while drilling holes. <ol style="list-style-type: none"> 1. Drill a single screw hole, making sure to hit a stud. 2. Insert and tighten the screw and hang the unit by the upper wall mounting bracket. 3. Determine the positions for the remaining four screws (two for the top bracket and two for the bottom), and remove the unit. 	<p style="text-align: center;">Location of Screw Hole</p>  <p style="text-align: center;">Locating Screw Holes</p>
Mounting	<ol style="list-style-type: none"> 4. Drill holes for the remaining four screws. 5. Hang the unit again by the first screw, and then insert and tighten the remaining four screws. 6. Take waterproofing measures so that water does not enter the building from screws mounting the device. 	<p style="text-align: center;">Anchoring Screw</p> 
Structure	<ul style="list-style-type: none"> • Make sure the unit is installed securely so that it will not fall or move due to vibrations or earthquakes. 	



10. Gas Piping

Follow the instructions from the gas supplier.

The appliance must be disconnected from the gas supply piping system during any pressure testing of that system at test pressures in excess of 3.5 kPa.

The appliance and its gas connections must be leak tested before placing the appliance in operation.

The inlet gas pressure must be within the range specified. This is for the purposes of input adjustment.

In order to choose the proper size for the gas line, consult local codes and / or the AS/NZS5601.

Gas Pressure

Size the gas line according to total MJ/h demand of the building and length from the meter or regulator so that the following supply pressures are available even at maximum demand refer AS/NZS5601:

Working Gas Supply Pressures

Natural Gas Supply Pressure

Min. 1.13 kPa

Max. 3.00 kPa

LP Gas Supply Pressure

Min. 2.75 kPa

Max. 3.50 kPa

- Please ensure measurement is taken when the appliance is operating at maximum load.

Gas Meter

Select a gas meter capable of supplying the entire MJ/h demand of all gas appliances in the building.

Gas Connection

- 1) Fit a union to the water heater gas inlet for easy connection and removal. The thread diameter is 20 mm. THIS DOES NOT INDICATE THE SIZE OF THE GAS SUPPLY.
- 2) Fit an AGA / NZGA approved isolating gas cock in the supply line adjacent to the water heater gas connection.
- 3) Ensure that the supply pipe and the gas pressure regulator (LPG or Natural Gas) has sufficient flow capacity for this and other appliances connected to the fitting line.
- 4) For LPG appliances ensure that gas cylinders are of sufficient size. The water heater alone will require 2 x 45 Kg capacity cylinders.
- 5) Before connecting the appliance to the gas service, purge any debris or air from the gas service.
- 6) Check all joints for leaks with an approved leak tester after connection.

Measuring Gas Pressure

In order to check the gas supply pressure to the unit, a tap is provided on the gas inlet. Remove the hex head philips screw from the tap, and connect a manometer using a silicon tube.

In order to check the gas manifold pressure on the gas valve inside the unit. The pressure can be checked by removing the hex head philips screw and connecting a manometer with a silicon tube.

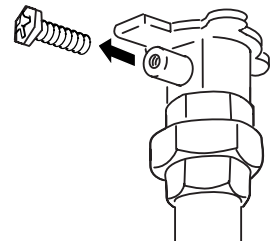

Refer to AS/NZS5601 for pipe sizing and details.

Ensure that the gas pipe size is correct. If undersized the appliance will not operate correctly

SERVICE CALLS ARE CHARGEABLE FOR UNITS WITH INCORRECT PIPE SIZES OR BLOCKED GAS OR WATER FILTERS.



11. Water Piping

Installation and service must be performed by a qualified plumber. Observe all applicable codes.

This appliance is suitable for potable water applications. Do not use this appliance if any part has been underwater. Immediately call a qualified service technician to inspect the appliance and replace any part of the control system and gas control which has been under water.

Piping and components connected to the water heater shall be suitable for use with potable water.

Toxic chemicals, such as those used for boiler treatment, shall not be introduced into the potable water.

A water heater used to supply potable water may not be connected to any heating system or components previously used with a nonpotable water heating appliance.

When water is required in one part of the system at a higher temperature than in the rest of the system, means such as a mixing valve shall be installed to temper the water to reduce the scald hazard.

- Flush water through the pipe to clean out metal powder, sand and dirt before connecting it.
- Perform the following insulation measures for prevention of freezing.
 - Take appropriate heat insulation measures (e.g., wrapping with heat insulation materials, using electric heaters) according to the climate of the region to prevent the pipe from freezing.
 - Make sure that there are no water leaks from the cold and hot water supply pipes, then insulate the pipes completely.
 - Be sure to also completely insulate the water supply valve and the cold and hot water connections on the water heater (refer to the figure on the right).
 - Do not cover the water drain plug with insulation so that water in the pipe can be drained. (Refer to the figure in the right.)
- Use a union coupling for connecting the pipes to reduce the force applied to the piping.
- When feed water pressure is too high, insert a depressurizing valve, or take water hammer prevention measure.
- Avoid using joints as much as possible to keep the piping simple.
- Avoid piping in which an air lock can occur.
- Use approved piping materials.
- If installing the unit on a roof (Above lower-level hot water supply):

If the unit is installed on a roof to supply water to the levels below, make sure that the water pressure supplied to the unit does not drop below 199 kPa. It may be necessary to install a pump system to ensure that the water pressure is maintained at this level.

Check the pressure before putting the unit into operation.

Failure to supply the proper pressure to the unit may result in noisy operation, shorter lifetime of the unit, and may cause the unit to shut down frequently.

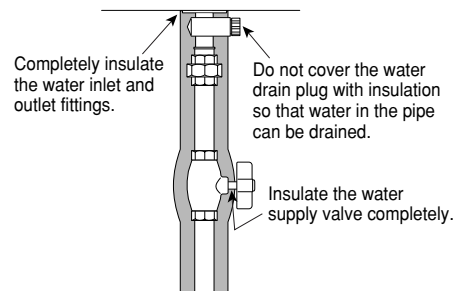

**Supply water piping**

- Do not use PVC, iron, or any piping which has been treated with chromates, boiler seal or other chemicals.
- Pipe sizing from the cold water supply should be sized according to local BY LAWS for water supply.
- If sludge or foreign matter is present in the water supply it is recommended that a separate filter/strainer be fitted to the cold water supply line.
- A GATE VALVE OR BALL VALVE must be used on the cold water inlet to the water heater. THIS REQUIREMENT IS AN AUSTRALIA WIDE REQUIREMENT UNDER THE NATIONAL PLUMBING CODE.

STOP TAPS OR COMBINATION STOP TAPS AND NON-RETURN VALVES ARE NOT TO BE USED.

- In order for the client to use the water heater comfortably, 200 to 1000 kPa of pressure is needed from the water supply. Be sure to check the water pressure. If the water pressure is low, the water heater cannot perform to its full capability, and may become a source of trouble for the client.

Drain processing

- Expansion water may drop from the pressure relief valve and wet the floor.

Hot water piping

- Do not use lead, PVC, iron or any piping which has been treated with chromates, boiler seal or other chemicals.
- Keep the pipe lengths to a minimum, and make sure that the pipework is well insulated as correct performance of the appliance is dependent on properly insulated pipework.
- DO NOT FIT ANY VALVES OR RESTRICTORS TO THE OUTLET OF THE WATER HEATER.
- DO NOT FIT ANY OBSTRUCTION TO THE PRESSURE RELIEF LOCATED ON THE HOT WATER OUTLET CONNECTION.
- Use mixing valves with low water resistance. Use shower heads with low pressure loss.
- If necessary, use a pump or other means to ensure that the supply water pressure to the inlet of the heater does not fall below 199kPa when the maximum amount of water is being demanded. Also install a pressure meter on the inlet. If this is not done, local boiling will occur inside the water heater causing abnormal sounds and decreasing the durability of the heat exchanger.

After purging the air from the system using the hot water supply taps, remove the water inlet strainer located on the cold water supply inlet connection. Remove any debris from the filter and replace. When replacing the filter, do not over-tighten the "O" ring seal.



It is recommended that for sanitary fixtures use primarily for the purpose of personal hygiene, that a temperature control device be fitted (such as a tempering valve) as per AS3498.



No pressure reduction valve is required unless the water pressure exceeds 1000 kPa.



12. Condensate Piping

PLEASE FOLLOW LOCAL CODES ABOUT CONDENSATE PIPING.

- This water heater is a high efficiency, fully condensing appliance which produces condensate during operation. Therefore, it is necessary to install condensate piping. The water heater incorporates a collection, neutralization, and removal system which must be properly drained in order to ensure proper operation of this appliance.
- The water heater is supplied with a pre-installed condensate neutralization system. No additional neutralizer is required unless local code dictates otherwise.
- In order to drain the condensate, a 15mm (1/2" BSP) male thread fitting is provided at the base of the water heater.

DO NOT FIT ANY VALVES OR REDUCE THE SIZE OF THIS FITTING OR THE CONDENSATE PIPING TO LESS THAN 15mm (1/2" BSP).

- Use plastic pipe, such as PVC, for the drain line. Do not use steel, black iron, or any other material which can corrode when placed into contact with water.
- Keep the length of the drain pipe as short as possible.
- Horizontal runs must be sloped 1/50 downwards the drain.
- The end of the drain pipe must not be submerged in water or blocked in any way.
- Be sure to check that condensate is freely flowing from the drain piping after the system has been installed. Condensate will begin flowing out of the water heater within 15 minutes after operation has started.
- Take measures to prevent the condensate drain lines from freezing (insulation, heat tape, electric heaters, etc.).

Condensate piping to floor drain

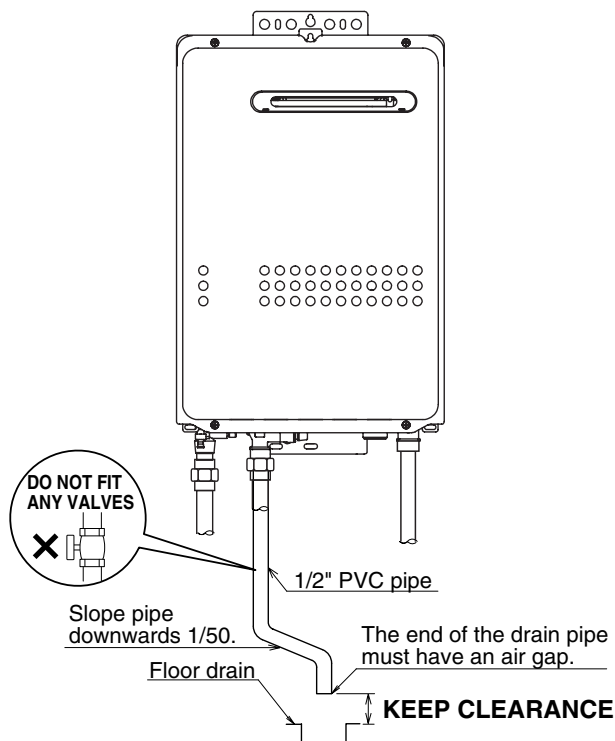



13. Electrical Wiring

Consult a qualified electrician for the electrical work.



Disconnect Power

Do not connect electrical power to the unit until all electrical wiring has been completed.

This appliance must be electrically earthed in accordance with Electrical Authority Regulations.

Caution: Label all wires prior to disconnection when servicing controls. Wiring errors can cause improper and dangerous operation.

Verify proper operation after servicing.

Field wiring to be performed at time of appliance installation.



WARNING

Electrical Shock Hazard

Do not turn power on until electrical wiring is finished. Disconnect power before servicing.

Failure to do so may result in death or serious injury from electrical shock.

- The appliance is equipped with a 1.5m cable with a three pinned earthed plug to be connected to 240/230VAC at 50 Hz.
The power consumption may be up to 185W.
Use an appropriate circuit.
- The appliance requires a 240V in Australia and 230V in New Zealand, 50Hz weatherproof plug installed in a protected position adjacent to the appliance.
- If the power cord is damaged and requires replacement, use only an original spare part available from the manufacturer.
- Do not disconnect the power supply when not in use. When the power is off, the freeze prevention in the water heater will not activate, resulting in possible freezing damage.
- Do not let the power cord contact the gas piping.

Tie the redundant power cord outside the water heater. Putting the redundant length of cord inside the water heater may cause electrical interference and faulty operation.

Earth

- To prevent electrical shock, always plug power lead into an earthed point.



CAUTION

Electrostatic discharge can affect electronic components. Take precautions to prevent electrostatic discharges from personnel or hand tools during the water heater installation and servicing to protect product's electronic control.



Remote Controller

Applicable Model

Remote controller		
Main controller	YPRM67XBN	Max temperature 60°C *
Bathroom controller	YPRS67XBN	Max temperature 50°C
Sub controller	YPRP62XBN	Max temperature 50°C

* Maximum temperature is controlled by the maximum default temperature set in the water heater.

The following combination of remote controls will operate the water heater.

Only Main Controller	Works
Only Bathroom Controller	Won't work
Only Sub Controller	Won't work
Main & Bathroom Controller	Works
Main, Bathroom & 1 or 2 Sub Controllers	Works
Main & Sub Controller	Won't work
Bathroom & Sub Controller	Won't work

The bathroom and sub controllers have a maximum temperature setting of 50°C for safety. To ensure compliance with Australian Standard AS/NZS3500.4, for sanitary areas, which may be achieved by using a Bosch appliance with a delivery temperature greater than 50°C and installed with a tempering valve. In New Zealand, please refer to the New Zealand Building Code and all other applicable electrical, gas fitting and plumbing codes.

Changing the Maximum Temperature install the remote controller according to the installation guide.

* The Bosch water heater has been factory set to allow a maximum temperature setting of 55°C.

To change the maximum temperature setting, connect the temperature selection wire as shown in the below diagram. The default temperature is 55°C when the temperature selection wire is not connected.

<The changing procedure of the maximum temperature setting.>

1. Turn the water heater off by pressing the ON/OFF button on the remote controller.
- 2. Disconnect electrical power to the water heater.**
3. Remove the front cover of the water heater (4 screws).
4. Locate bridge attached to the inside of the front cover, and insert the bridge into plastic clip between the remote controller terminals as shown on the right.
5. Replace the front cover of the water heater (4 screws).
6. Reconnect electrical power to the water heater.

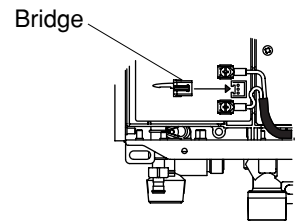
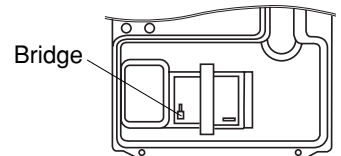

Remote controller		BC2680RA	BC2180RA	BC2680RA5	BC2180RA5
		Factory Setting	Connector in	Factory Setting	Connector in
Main controller	YPRM67XBN	37 - 55°C	37 - 60°C	37 - 50°C	37 - 42°C
Bathroom controller	YPRS67XBN	37 - 50°C	37 - 50°C	37 - 50°C	37 - 42°C
Sub controller	YPRP62XBN	37 - 50°C	37 - 50°C	37 - 50°C	37 - 42°C

* Bath Fill temperature setting is 37 - 48°C.



WARNING

- When changing the temperature, make sure to confirm with the customer that the temperature of the hot water will be very high and that there is a risk of scalding.



It is recommended that for sanitary fixtures use primarily for the purpose of personal hygiene, that a temperature control device be fitted (such as a tempering valve) as per AS3498.



Connecting Remote Controller Cord to Unit

- Tie the redundant cord outside the water heater. Do not put the extra length inside the water heater.
- The remote controller cord can be extended up to 20m.
- Be sure to hand tighten when screwing to the terminal block. Power tools may cause damage to the terminal block.

Remote controller cord

- Use remote controller cord for any extensions.
- Install according to the National Electrical Code and all applicable local codes.

1. Disconnect electrical power to the water heater.
2. Leave enough slack so that the remote controller cord will not be damaged if the unit is removed from the wall.
3. Remove the front cover of the heater (4 screws).
4. Pass the remote controller cord through the wiring throughway and into the unit.
5. Connect the Y terminals at the end of the remote controller cord to the terminal block.
6. Secure the remote controller cord with a clamp.
7. Replace the front cover.

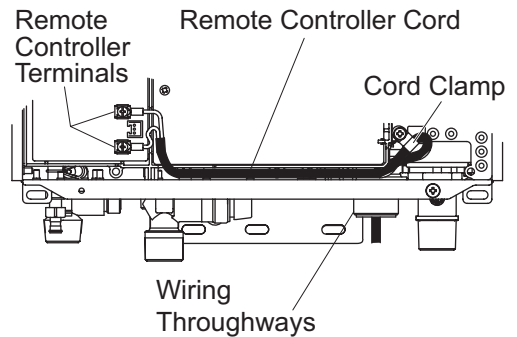



14. Maintenance

Periodically check the following to ensure proper operation of the water heater.

- The venting system must be examined periodically by a qualified service technician to check for any leaks or corrosion.
- The burner flame must be checked periodically for a proper blue colour and consistency.
- If the flame does not appear normal, the burner may need to be cleaned.
- If the burner needs to be cleaned, it must be performed by a qualified service technician.
- Do not obstruct the flow of combustion and ventilation air.
- See Owner's Guide for further maintenance or consult Bosch Hot Water for recommended service checks.

Warning: There is a scald potential if the output temperature is set too high.

Should overheating occur, or the gas supply fail to shut off, turn off the manual gas control valve to the appliance.

Do not use this appliance if any part has been under water. Immediately call a qualified service technician to inspect the appliance and to replace any part of the control system and any gas control which has been under water.

Periodically check and clean the filter inside the cold water inlet of the unit.

Servicing by qualified technician should be performed every two years.

15. Trial Operation

The installer should test operate the unit, explain to the customer how to use the unit, and give the owner this manual before leaving the installation.

- Preparation
 - (1) Open a hot water fixture to confirm that water is available, and then close the fixture.
 - (2) Open the gas supply valve.
 - (3) Turn on the power supply. Using the remote controller, turn on the Power On/Off button (the Operation lamp will turn on).

- (1) Open a hot water fixture and confirm that the Burner On lamp comes on, and that hot water is being produced. (If necessary, repeat until the air in the gas piping is bled out).
 - * White smoke may be noticed from the exhaust vent during cold weather. However, this is not a malfunction of the unit.
 - * If an "11" error code appears on the remote controller, turn the unit off and then back on again, and then open a hot water fixture again.
 - (2) Change the temperature setting on the remote controller and check that the water temperature changes.
- If the water heater does not operate normally, refer to "Troubleshooting" in the Owner's Guide.
 - * After the trial operation, clean the filter in the cold water inlet.



CAUTION

Handling after trial operation

- If the unit will not be used immediately, close off all gas and water shutoff valves, drain all of the water out of the unit and the plumbing system to prevent the unit and system from freezing, and bleed the gas out of the gas line.
Freezing is not covered by the warranty.

**WARNING**

A fire or explosion may result if these instructions are not followed, which may cause loss of life, personal injury or property damage.

Lighting Instructions

This water heater does not have a pilot. It is equipped with an ignition device that automatically lights the burner.

Do not try to light the burner by hand.

1. Read the safety information in the installation manual or on the right side of the water heater.
2. Turn off all electrical power to the unit.
3. Do not attempt to light the burner by hand.
4. Turn the gas control manual valve (external to the unit) clockwise to the off position.
5. Wait five minutes to clear out any gas. If the smell of gas remains, stop, and follow the instructions on page 3 of Owner's Guide.
6. Turn the gas control manual valve counterclockwise to the on position.
7. Turn on electric power to the unit.
8. The unit will now operate whenever hot water is called for. If the unit will not operate, follow the shutdown instructions and call a service technician.

Shutdown Instructions

1. Stop any water demand.
2. Turn off electric power.
3. Turn the gas control manual valve clockwise to the off position.

Should overheating occur, or the gas supply fail to shut off, turn off the manual control valve to the appliance.



WATER QUALITY

All Bosch water heating appliances are constructed from high quality materials and components and all are certified for compliance with relevant parts of Australian and New Zealand gas, electrical and water standards.

Whilst Bosch water heaters are warranted against defects, the warranty is conditional upon correct installation and use, in accordance with detailed instructions provided with the heater. In the case of the water supplied to the heater, it is important that the water quality be of acceptable standard.

The water quality limits/parameters listed in water quality table are considered acceptable and generally, Australian and New Zealand suburban water supplies fall within these limits/parameters.

In areas of Australia and New Zealand where water may be supplied, either fully or partly, from bores, artesian wells or similar, one or more of the important limits may well be exceeded and the heater could, therefore, be at risk of failure.

Where uncertainty exists concerning water quality, intending appliance users should seek a water analysis from the water supplying authority and in cases where it is established that the water supply does not meet the quality requirements of the water quality table, the Bosch warranty would not apply.

WATER QUALITY TABLE

Maximum levels

pH	Saturation Index(LSI) (langelier)	Total Hardness	Chlorides	Sodium	Iron
6.5-9	+0.4 to Minus 1.0 @65C	200mg/l	250mg/l	180mg/l	1mg/l